

# Catalogo Ricambi

2015 v 3.0

# KZ10B

## 23/M/21

Ultimo aggiornamento  
(Last Update):

18/06/2015

**tm**  
KART



## TAV. 01 – CILINDRO (Cylinder)

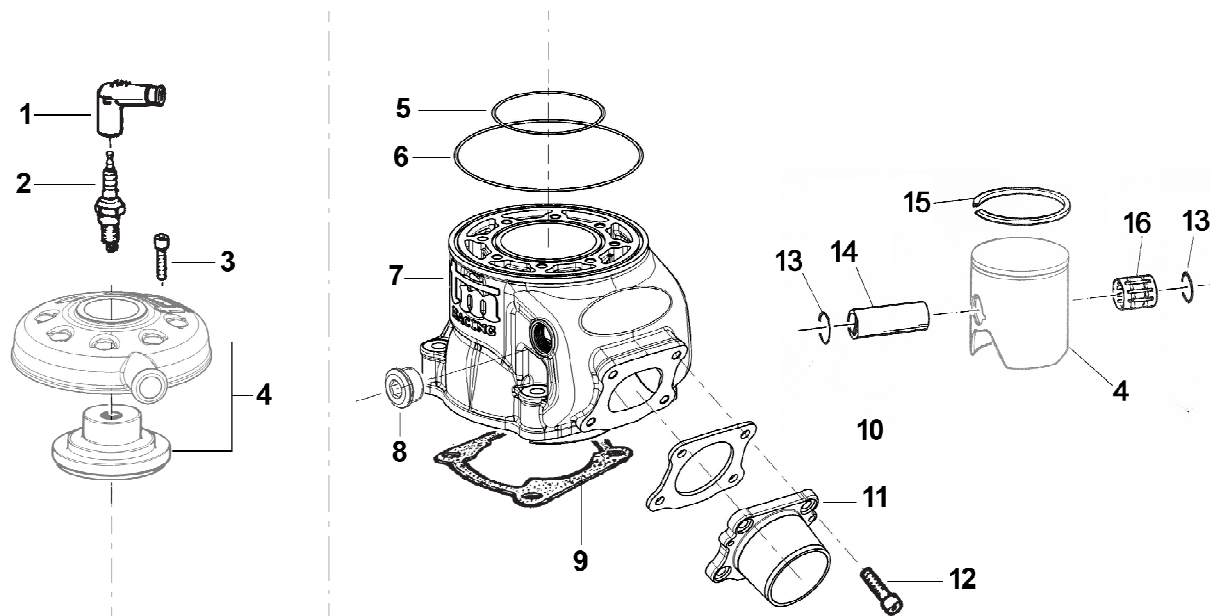

Pos	Codice	Q.tà	KZ10-B	Note	Descrizione (ITA)	Description (ENG)
1	21014	1			PIPETTA CANDELA	Cap, Spark plug
2	06024	1			CANDELA	Spark Plug
3	49486	8			VITE TCEI 6 x 30	Screw
4					VEDI TAV.02 PAG. 3	SEE TAV.02 PAGE 3
5	12003	1			O-RING INTERNO	O-ring, small
6	12014	1			O-RING ESTERNO	O-ring, large
7	01561	1			CILINDRO	Cylinder
8	49883	-	KZ10-B		TAPPO CILINDRO	Plug, Cylinder
9	05053.05	-	KZ10-B		GUARN. BASE CILINDRO 0,05 mm	Gasket 0,05 mm
	05053.10	-	KZ10-B		GUARN. BASE CILINDRO 0,10 mm	Gasket 0,10 mm
	05053.15	-	KZ10-B		GUARN. BASE CILINDRO 0,15 mm	Gasket 0,15 mm
	05053.20	-	KZ10-B		GUARN. BASE CILINDRO 0,20 mm	Gasket 0,20 mm
	05053.30	-	KZ10-B		GUARN. BASE CILINDRO 0,30 mm	Gasket 0,30 mm
	05053.40	-	KZ10-B		GUARN. BASE CILINDRO 0,40 mm	Gasket 0,40 mm
	05053.50	-	KZ10-B		GUARN. BASE CILINDRO 0,50 mm	Gasket 0,50 mm
10	05027	1			GUARNIZIONE SCARICO	Gasket, Exhaust
	13069.5	-		Opt.	SPESSORE COLLETTORE SCARICO 5mm	Spacer, Exhaust manifold
	13069.3	-		Opt.	SPESSORE COLLETTORE SCARICO 3mm	Spacer, Exhaust manifold
11	13062	1			COLLETTORE SCARICO	Manifold, Exhaust
	13071+	-			COLLETTORE SCARICO 13071+	Manifold, Exhaust
	13071+C	-			COLLETTORE SCARICO 13071+C	Manifold, Exhaust
12	49484	4			VITE TCEI 6 x 20	Screw
13	09004	2			ANELLINI SPINOTTO (*)	Clip, piston pin (*)
14	09000	1			SPINOTTO PISTONE (*)	Pin piston (*)
15	11056	1			SEGMENTO (*)	Piston ring (*)
16	19033	1			GABBIA SPINOTTO	Top end bearing
					(*) Inclusi nel Pistone	(*) Included in the Piston

## TAV. 02 - TESTA E PISTONE (Head and Piston)

### TESTA E PISTONE STANDARD (Head and Piston Standard)

In tutti I motori standard, se non richiesto diversamente.  
(In all standard engines, unless otherwise requested)

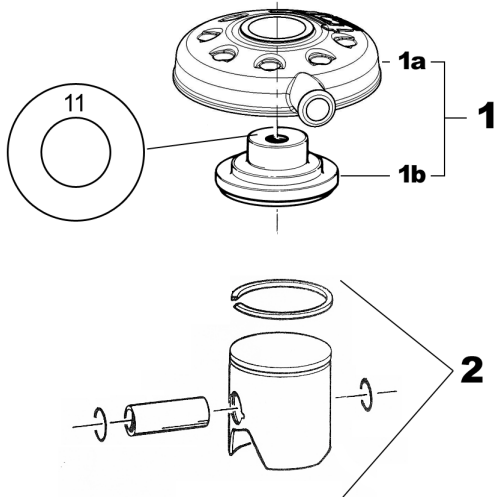

Pos.	Code	Descrizione (ITA)	Description (ENG)
<b>1</b>	<b>02555</b>	<b>TESTA "11"</b>	Head
<b>1a</b>	<b>02554</b>	<b>COPERCHIO TESTA</b>	Cover, Head
<b>1b</b>	<b>02555.2</b>	<b>CAMERA COMBUSTIONE "11"</b>	Insert, Head
<b>2</b>	<b>10087.93</b>	<b>PISTONE 53,93 - CPL (*)</b>	Piston 53,93 - Assy (*)
	<b>10087.94</b>	<b>PISTONE 53,94 - CPL (*)</b>	Piston 53,94 - Assy (*)
	<b>10087.95</b>	<b>PISTONE 53,95 - CPL (*)</b>	Piston 53,95 - Assy (*)
	<b>10087.96</b>	<b>PISTONE 53,96 - CPL (*)</b>	Piston 53,96 - Assy (*)
	<b>10087.97</b>	<b>PISTONE 53,97 - CPL (*)</b>	Piston 53,96 - Assy (*)
	<b>10087.98</b>	<b>PISTONE 53,98 - CPL (*)</b>	Piston 53,93 - Assy (*)
	<b>10047.92</b>	<b>PISTONE 53,92 Light - CPL (*)</b>	Piston 53,92 - Assy (*)
	<b>10047.93</b>	<b>PISTONE 53,93 Light - CPL (*)</b>	Piston 53,93 - Assy (*)
	<b>10047.94</b>	<b>PISTONE 53,94 Light - CPL (*)</b>	Piston 53,94 - Assy (*)
	<b>10047.95</b>	<b>PISTONE 53,95 Light - CPL (*)</b>	Piston 53,95 - Assy (*)
	<b>10047.96</b>	<b>PISTONE 53,96 Light - CPL (*)</b>	Piston 53,96 - Assy (*)

(\*) Completo di Segmento+Anellini+Spinotto  
(\*) Assy with Ring+Clips+Pin



**I Pistoni standard codice 10087.xx e 10047.xx possono essere montati solo con la testa "11"**  
(Pistons standard code 10087.xx and 10047.xx can be only mounted with "11" head)

### TESTA E PISTONE 4 GRADI (Head and Piston 4 degree)

In tutti i motori preparati.  
(In all tuned engines)

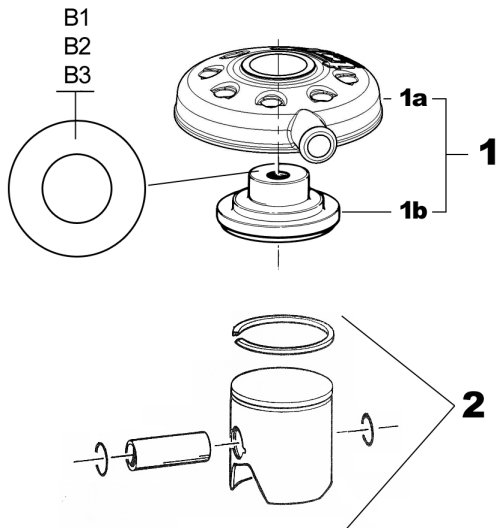

Pos.	Code	Descrizione (ITA)	Description (ENG)
<b>1</b>	<b>02556.B1</b>	<b>TESTA B1</b>	Head B1
	<b>02556.B2</b>	<b>TESTA B2</b>	Head B2
	<b>02556.B3</b>	<b>TESTA B3</b>	Head B3
<b>1a</b>	<b>02554</b>	<b>COPERCHIO TESTA</b>	Cover, Head
<b>1b</b>	<b>02555.B1</b>	<b>CAMERA COMBUSTIONE B1</b>	Insert, Head
	<b>02555.B2</b>	<b>CAMERA COMBUSTIONE B2</b>	Insert, Head
	<b>02555.B3</b>	<b>CAMERA COMBUSTIONE B3</b>	Insert, Head
<b>2</b>	<b>10049.93</b>	<b>PISTONE 53,93 - 4° CPL (*)</b>	Piston 53,93 - Assy (*)
	<b>10049.94</b>	<b>PISTONE 53,94 - 4° CPL (*)</b>	Piston 53,94 - Assy (*)
	<b>10049.95</b>	<b>PISTONE 53,95 - 4° CPL (*)</b>	Piston 53,95 - Assy (*)
	<b>10049.96</b>	<b>PISTONE 53,96 - 4° CPL (*)</b>	Piston 53,96 - Assy (*)
	<b>10049.97</b>	<b>PISTONE 53,97 - 4° CPL (*)</b>	Piston 53,96 - Assy (*)
	<b>10049.98</b>	<b>PISTONE 53,98 - 4° CPL (*)</b>	Piston 53,93 - Assy (*)
	<b>10045.93</b>	<b>PISTONE 53,93 Light - 4° CPL (*)</b>	Piston 53,93 - Assy (*)
	<b>10045.94</b>	<b>PISTONE 53,94 Light - 4° CPL (*)</b>	Piston 53,94 - Assy (*)
	<b>10045.95</b>	<b>PISTONE 53,95 Light - 4° CPL (*)</b>	Piston 53,95 - Assy (*)
	<b>10045.96</b>	<b>PISTONE 53,96 Light - 4° CPL (*)</b>	Piston 53,96 - Assy (*)
	<b>10045.97</b>	<b>PISTONE 53,97 Light - 4° CPL (*)</b>	Piston 53,97 - Assy (*)
	<b>10045.98</b>	<b>PISTONE 53,98 Light - 4° CPL (*)</b>	Piston 53,98 - Assy (*)

(\*) Completo di Segmento+Anellini+Spinotto (\*) Assy with Ring+Clips+Pin



**I Pistoni 4° codice 10049.xx e 10045.xx possono essere montati solo con le teste B1/B2/B3**  
(Pistons 4° code 10049.xx and 10045.xx can be only mounted with "B1/B2/B3" head)

**TAV. 03 – ALBERO MOTORE CON BIELLA Ø 20**  
(Crankshaft with 20mm Conrod kit)

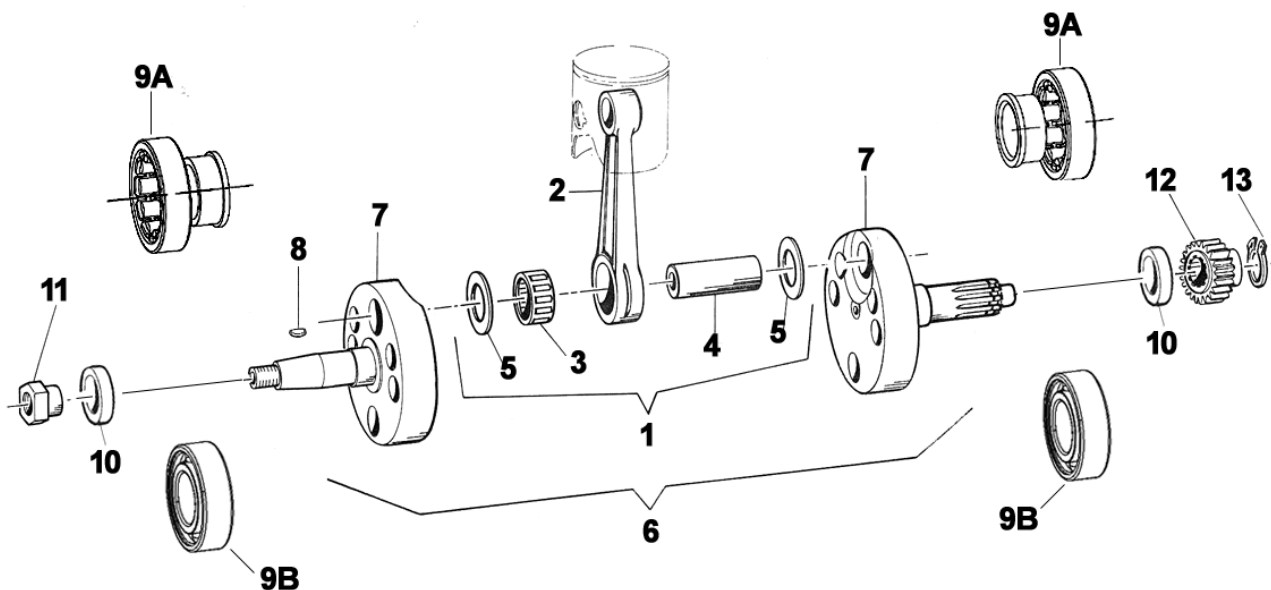

Pos	Codice	Q.tà	KZ10-B	Note	Descrizione (ITA)	Description (ENG)
1	18052.3	-			BIELLA CPL – ASSE 20 Foro 5	Conrod kit – Pin Ø 20 with 5mm hole
	18052.1	-			BIELLA CPL – ASSE 20 Foro 6	Conrod kit – Pin Ø 20 with 6mm hole
	18052	-			BIELLA CPL – ASSE 20 Foro 8	Conrod kit – Pin Ø 20 with 8mm hole
	18052.2	-			BIELLA CPL – ASSE 20 Pieno	Conrod kit – Pin Ø 20 Solid
2	18119	-			BIELLA LUCIDA CPL – ASSE 20 Foro 5	Conrod kit Polished – Pin Ø 20 with 5mm hole
	18119.1	-			BIELLA LUCIDA CPL – ASSE 20 Foro 6	Conrod kit Polished – Pin Ø 20 with 6mm hole
	18119.2	-			BIELLA LUCIDA CPL – ASSE 20 Foro 8	Conrod kit Polished – Pin Ø 20 with 8mm hole
	18119.3	-			BIELLA LUCIDA CPL – ASSE 20 Pieno	Conrod kit Polished – Pin Ø 20 Solid
2	18053	1			BIELLA NUDA	Conrod
	18118	-			BIELLA LUCIDA NUDA	Conrod Polished
3	17020	1			GABBIA ARGENTATA Ø 20	Silver Bearing Ø 20
4	18062.1	-			ASSE 20 x 50,4 Foro 5	Pin Ø 20 with 5mm hole
	18062.4	1			ASSE 20 x 50,4 Foro 6	Pin Ø 20 with 6mm hole
	18062	-			ASSE 20 x 50,4 Foro 8	Pin Ø 20 with 8mm hole
	18062.2	-			ASSE 20 x 50,4 Pieno	Pin Ø 20 Solid
5	18061	2			RONDELLA ARGENTATA	Washer, Silver
6	18185	-			ALBERO MOTORE CPL BIELLA 20	
7	18179	1			COPPIA SEMIALBERI	
8	49010	1			CHIAVETTA	Woodruff key
9A	03029	2		Opt.	CUSCINETTI A RULLI	Roller Bearing
9B	03004	2			CUSCINETTI A SFERE	Ball Bearing
10	04000	2			PARAOLIO 20 x 35 x 7	Oil Seal
11	49056	1			DADO ACCENSIONE	Nut, Ignition
12	40313	1			PIGNONE COPPIA Z 19	Primary Gear 19 T
13	49216	1			SEEGER	Snap Ring

**TAV. 04 – ALBERO MOTORE CON BIELLA Ø 22**  
(Crankshaft with 22mm Conrod kit)

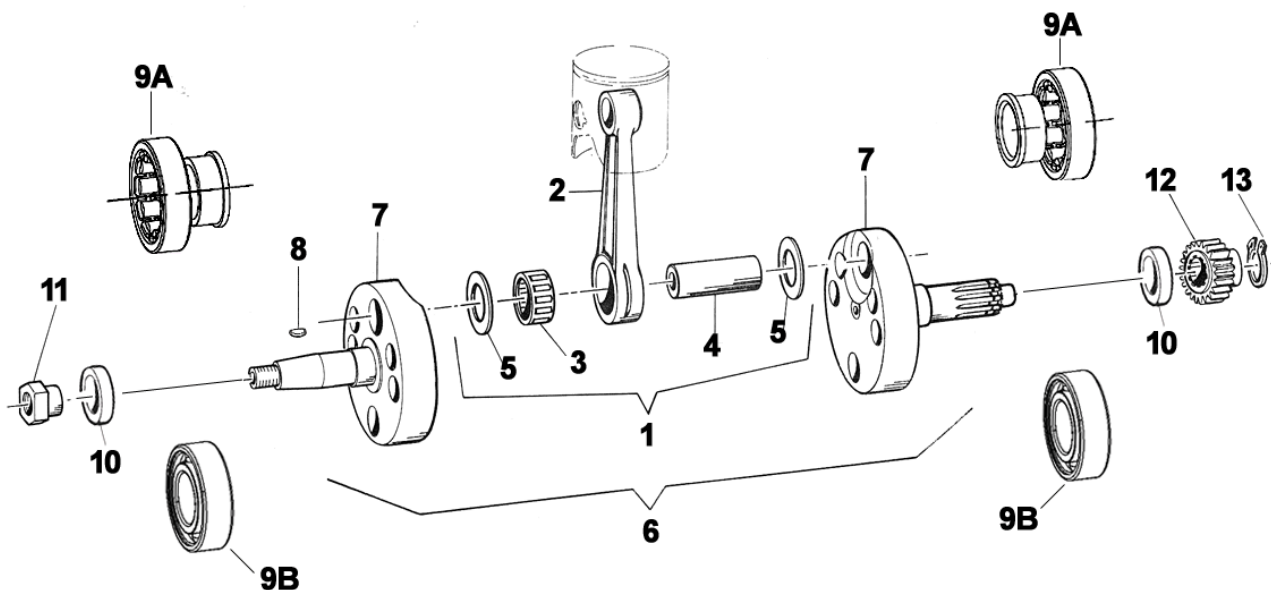

Pos	Codice	Q.tà	KZ10-B	Note	Descrizione (ITA)	Description (ENG)
1	18125	-	KZ10-B	Ø22	BIELLA CPL – ASSE 22 Foro 6	Conrod kit – Pin Ø 22 with 6mm Hole
	18125.2	-	KZ10-B	Ø22	BIELLA CPL – ASSE 22 Foro 5	Conrod kit – Pin Ø 22 with 5mm Hole
2	18053.2	1	KZ10-B	Ø22	BIELLA NUDA	Conrod
3	17015	1	KZ10-B	Ø22	GABBIA ARGENTATA Ø 22	Silver bearing
4	18091	1	KZ10-B	Ø22	ASSE 22 x 50,4 Foro 6	Pin Ø 22 with 6mm Hole
	18025	-	KZ10-B	Ø22	ASSE 22 x 50,4 Foro 5	Pin Ø 22 with 5mm Hole
5	18239	2	KZ10-B	Ø22	RONDELLA ARGENTATA	Washer, Silver
6	18263	-	KZ10-B	Ø22	ALBERO MOTORE CPL BIELLA 22	Crankshaft Assy
7	18150	1	KZ10-B	Ø22	COPPIA SEMIALBERI	
8	49010	1			CHIAVETTA	Woodruff key
9A	03029	2		Opt.	CUSCINETTI A RULLI	Roller Bearing
9B	03004	2			CUSCINETTI A SFERE	Ball Bearing
10	04000	2			PARAOILIO 20 x 35 x 7	Oil Seal
11	49056	1			DADO ACCENSIONE	Nut, Ignition
12	40313	1			PIGNONE COPPIA Z 19	Primary gear 19 T
13	49216	1			SEEGER	Snap Ring

**Tav. 05 – PACCO LAMELLARE**

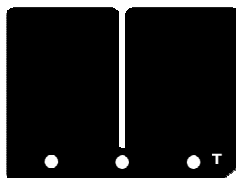
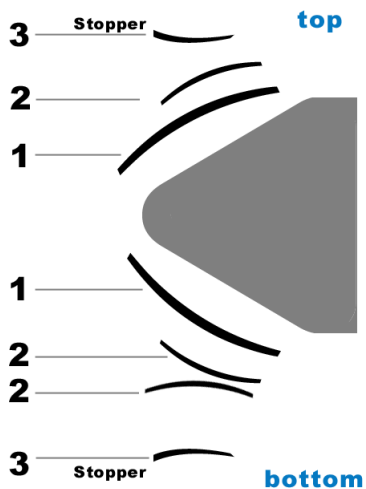

1. Cod. 20062.2  
Lamella MAGMALYTE Superiore



2. Cod. 20049  
Balestrino

Pos.	Codice	Descrizione	Note
1	20062.2	Lamella Carbonio 0,34 "T" Special MAGMALYTE Reeds	<b>Il codice è per un solo pezzo</b> The code is for one piece
2	20049	Balestrino per lamella Carbon stopper	<b>Il Codice è per una coppia (2 pezzi) di Balestrini</b> The code is for one pair of stoppers
3	20059	Coppia Stopper per lamelle speciali Metal stoppers	<b>Il Codice è per una coppia (2 pezzi) di stoppers</b> The code is for one pair of stoppers

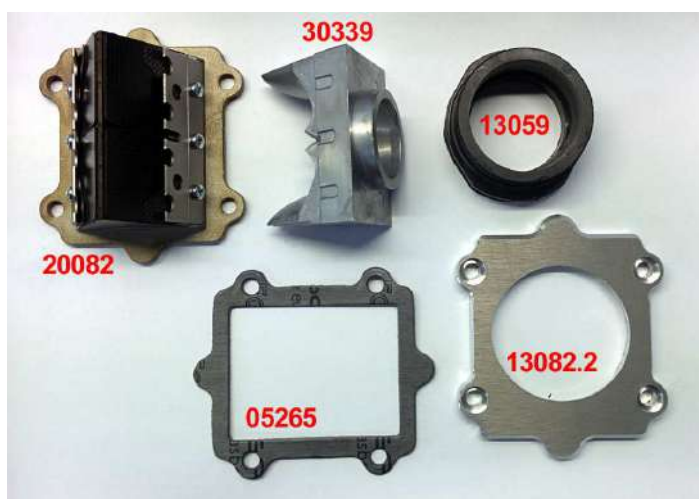

Tav. 06 – FRIZIONE

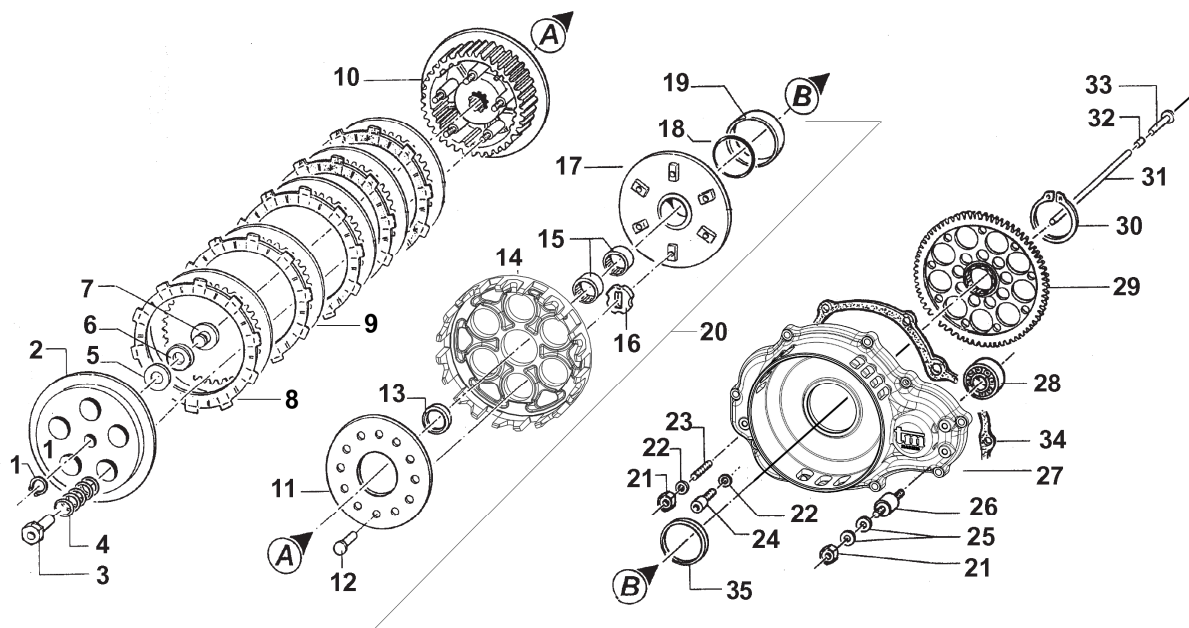

Pos	Codice	Q.tà	KZ10-B	Note	Descrizione (ITA)	Description (ENG)
1	49211	1			SEEGER	
2	35025	1			PIATTO SPINGIDISCO	
3	49057	5			DADO FRIZIONE ERGAL	
4	16035	5			MOLLA FRIZIONE	
5	19021	1			RONDELLA	
6	19020	1			GABBIA A RULLI RADIALE	
7	26001	1			REGGISPINTA FRIZIONE	
8	35017	5			DISCO FRIZIONE GUARNITO	
9	35008	5			DISCO FRIZIONE ACCIAIO 1,5mm	
10	25093	1	KZ10-B		TAMBURELLO FRIZIONE	
11	35026	1	KZ10-B		DISCO BATTUTA GOMMINI	
12	49727	6			VITE	
13	04008	1			PARAOLIO 20 x 26 x 4	
14	25006	1	KZ10-B		CAMPANA FRIZIONE	
15	19040	2			GABBIA A RULLI HK 2012	
16	21005.1	6		New	GOMMINO PARASTRAPPI	
17	40387	1			MOZZO	
18	12036	1			O-RING	
19	26000	1			BOCCOLA	
20	40376	-	KZ10-B		MOZZO COMPLETO	
21	49637	1			DADO M6 AUTOBLOCK	
22	49104	2			RONDELLA Ø6	
23	49710	1			GRANO 6 x 30	
24	49480	1			VITE TCEI 6 x 10	
25	49603	4			RONDELLA 6 x 12	
26	21003	2			SILENT BLOCK	
27	30154	1	KZ10-B		COPERCHIO FRIZIONE	
28	03019	1			CUSCINETTO 6202 C4	
29	40385	1			COPPIA PRIMARIA Z 75	
30	49251	1			SEEGER	
31	35052	1	KZ10-B		ASTINA FRIZIONE 146,2 mm	
32	19006	1			RULLINO	
33	35030	1			ASTINA A FUNGO	
34	05115	1			GUARNIZIONE	
35	04007.2	1		New	PARAOLIO 40 x 52 x 5 CON ANELLO IN METALLO	
	04007	-			PARAOLIO 40 x 52 x 5	
	04007.1	-			PARAOLIO 40 x 52 x 5 (TEFLON)	



**TAV. 07 – BASAMENTO MOTORE  
(Crankcase)**

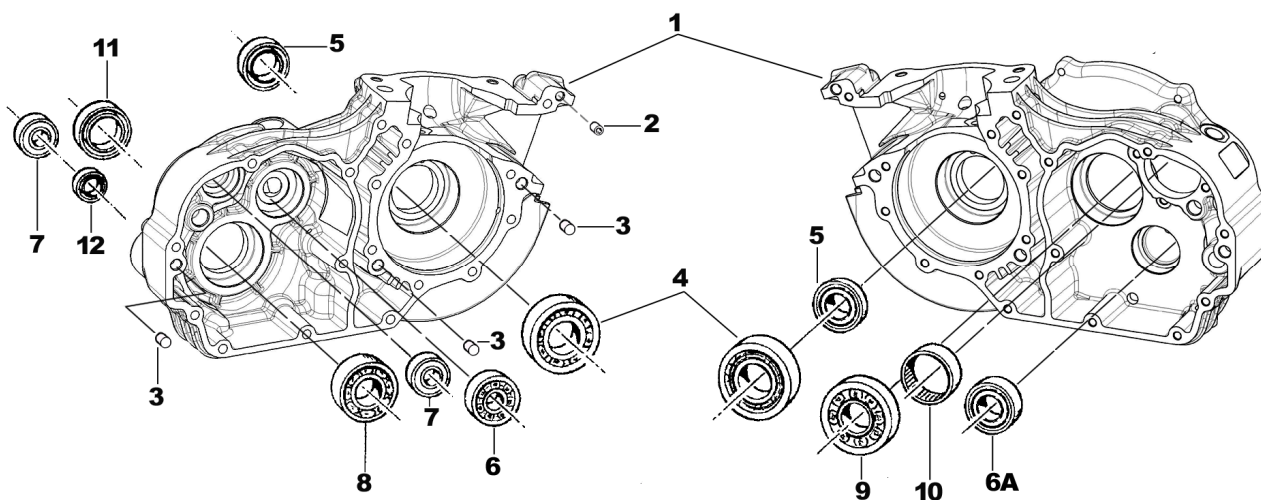

Pos	Codice	Q.tà	KZ10-B	Note	Descrizione (ITA)	Description (ENG)
1	30156	1			BASAMENTO MOTORE	
	30157	-			BASAMENTO MOTORE CPL	
2	19036	1			RULLO 6 x 12	
3	26091	2			RULLO 8 x 12	
4	03004	2			CUSCINETTO AB.41272.S02	
	03004.1	-			CUSCINETTO AB.41272.S01	
	03029	-		Opt	CUSCINETTO A RULLI	
5	04000	2			PARAOLIO 20 x 35 x 7	
6	03080	1		New	CUSCINETTO BB1-0722 DB VK	
6A	03009	1			CUSCINETTO 6202 Z C3	
7	03012	2			CUSCINETTO 6001 2 RS	
8	03010	1			CUSCINETTO 6204 C3	
	03073	1			CUSCINETTO A RULLI NJ 204ET2X	
9	03252	1			CUSCINETTO 6205 C4	
10	19041	1			GABBIA A RULLI DHK 35/12	
11	04003	1			PARAOLIO 26 x 37 x 7	
12	04004	1			PARAOLIO 12 x 22 x 5	

## TAV. 08/1 – ALBERO PRIMARIO CAMBIO (Mainshaft)

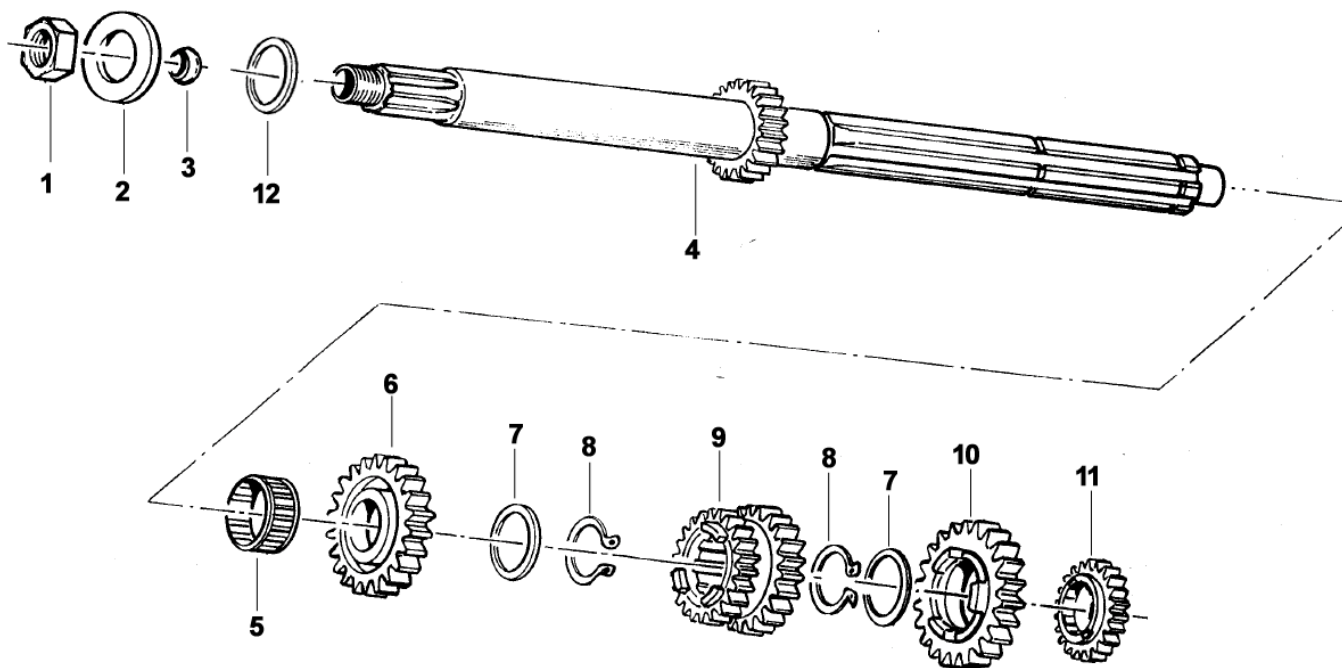

Pos	Codice	Q.tà	KZ10-B	Note	Descrizione (ITA)	Description (ENG)
1	49052	1			DADO TAMBURELLO	Nut
2	48002	1			SPESSORE 30 x 18 x 3	Spacer
3	04009	1			PARAOLIO 5 x 9 x 2	Oil Seal
4	40425	±			ALBERO-PRIMARIO Z 13	
	40429	±			ALBERO-PRIMARIO Z 13	
					VEDERE TAV. 08/2 PER L'AGGIORNAMENTO	SEE TAV. 08/2 FOR UPTADE
5	19012	1			GABBIA A RULLI 20 x 24 x 10	Needle bearing
6	40440	1			INGRANAGGIO 5^ A.P. Z 22	Gear 5th 22 T
7	48013	2			RASAMENTO 27 x 20 x 0.7	Shim
8	49216	2			SEEGER Ø 20	Seeger
9	40437	1			INGRANAGGIO A.P. 3/4^ Z 18/22	Gear 3/4 18/22 T
10	40454	1			INGRANAGGIO A.P. 6^ Z 27	Gear 6th 27 T
11	40422	1			INGRANAGGIO A.P. 2^ Z 16	Gear 2nd 16 T
12	48003	1			SPESSORE 30 x 20 x 2	Spacer

Cambio KZ10-B ( Gear Box )				
Marcia (Gear)	Primario (Mainshaft)		Secondario (Countershaft)	
	Denti (Teeths)	Codice (Code)	Denti (Teeths)	Codice (Code)
1^	13	40439	33	40472
2^	16	40422	29	40484
3^	18	40437	27	40495
4^			27	40503
5^	22	40440	23	40515
6^	27	40454	25	40536

**TAV. 08/2 – ALBERO PRIMARIO CAMBIO – Agg. Settembre 2014**  
(Mainshaft – Update September 2014)

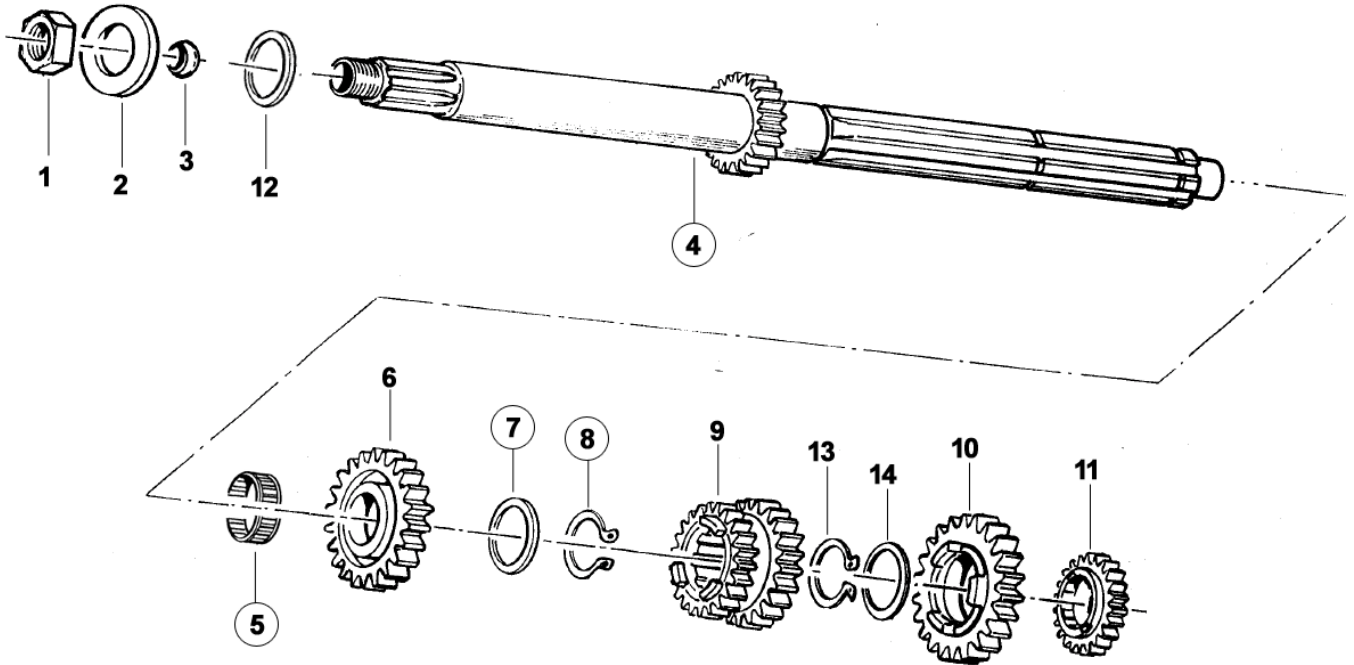

Pos	Codice	Q.tà	KZ10-B	Note	Descrizione (ITA)	Description (ENG)
1	49052	1			DADO TAMBURELLO	Nut
2	48002	1			SPESSORE 30 x 18 x 3	Spacer
3	04009	1			PARAOILIO 5 x 9 x 2	Oil Seal
4	40439	1		Update	ALBERO PRIMARIO Z 13 (compresivo di pos. 5+7+8)	Primary Shaft 13 T (including pos. 5+7+8)
5	19069	1		Update	GABBIA A RULLI in 2 pezzi	Needle bearing
6	40440	1			INGRANAGGIO 5 <sup>^</sup> A.P. Z 22	Gear 5th 22 T
7	48041	1		Update	RASAMENTO 27,5 x 21 x 1	Shim
8	49222	1		Update	SEEGER Ø 21	Seeger
9	40437	1			INGRANAGGIO A.P. 3/4 <sup>^</sup> Z 18/22	Gear 3/4 18/22 T
10	40454	1			INGRANAGGIO A.P. 6 <sup>^</sup> Z 27	Gear 6th 27 T
11	40422	1			INGRANAGGIO A.P. 2 <sup>^</sup> Z 16	Gear 2nd 16 T
12	48003	1			SPESSORE 30 x 20 x 2	Spacer
13	48013	1			RASAMENTO 27 x 20 x 0.7	Shim
14	49216	1			SEEGER Ø 20	Seeger

l'albero primario cod. **40439** sostituisce gli alberi cod. 40429 e cod. 40425 ma deve essere usato solo ed esclusivamente con i seguenti particolari:

- pos. 5 cod. 19069 – Gabietta a rulli in 2p
- pos. 7 cod. 48041 – Rasamento 27,5 x 21 x 1
- pos. 8 cod. 49222 – Seeger Ø 21 rettificato

The Primary shaft code **40439** replace shafts code 40429 and 40425 but must be used exclusively with the following items:

- pos. 5 cod. 19069 – Needle bearing 2p
- pos. 7 cod. 48041 – Shims 27,5 x 21 x 1
- pos. 8 cod. 49222 – Seeger Ø 21 rectified

## Tav. 09 – ALBERO SECONDARIO CAMBIO (Countershaft)

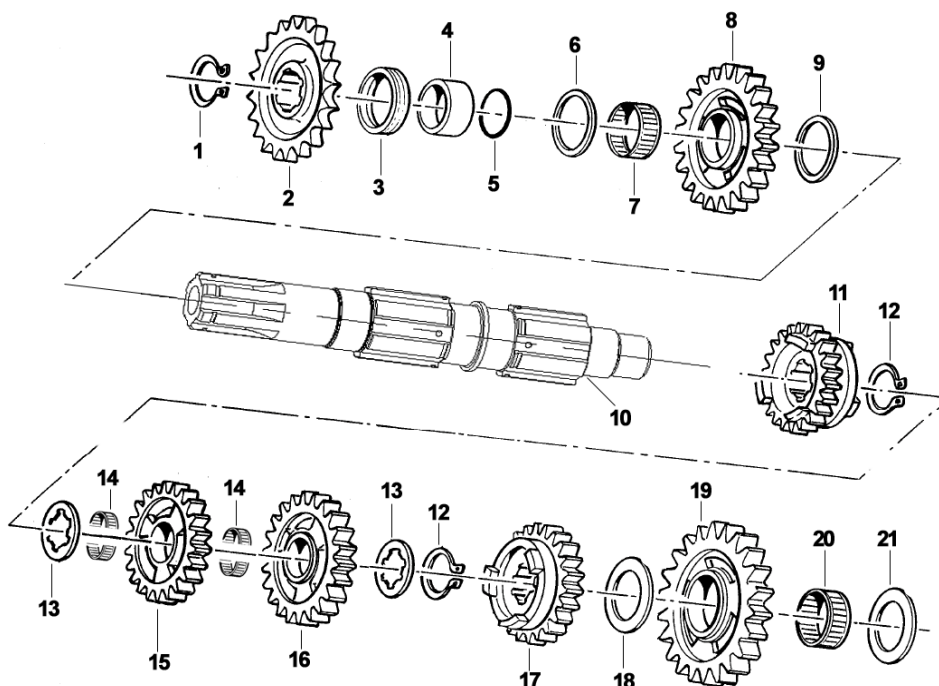

Pos	Codice	Q.tà	KZ10-B	Note	Descrizione (ITA)	Description (ENG)
1	49216	1			SEEGER	Snap Ring
2	40066.15	-			PIGNONE CATENA Z 15	Front Sprocket 15 T
	40066.16	-			PIGNONE CATENA Z 16	Front Sprocket 16 T
	40066.17	1			PIGNONE CATENA Z 17	Front Sprocket 17 T
	40066.18	-			PIGNONE CATENA Z 18	Front Sprocket 18 T
	40019	-			PIGNONE CATENA Z 19	Front Sprocket 19 T
	40020	-			PIGNONE CATENA Z 20	Front Sprocket 20 T
	40021	-			PIGNONE CATENA Z 21	Front Sprocket 21 T
3	04003	1			PARAOLIO	Oil Seal
4	26002	1			DISTANZIALE	Collar
5	12019	1			O-RING	O-Ring
6	48038	1	KZ10-B		RASAMENTO 30 x 20 x 2	Sapcer
7	19062	1	KZ10-B		GABBIA A RULLI	Needle cage
8	40484	1	KZ10-B	X	INGRANAGGIO 2a AS Z 29	Gear 2 <sup>nd</sup> 29 T Countershaft
9	48035	1	KZ10-B		RASAMENTO 30 x 21 x 0,5	Washer
10	40466	1	KZ10-B	X	ALBERO SECONDARIO	Countershaft
11	40536	1	KZ10-B		INGRANAGGIO 6° AS Z 25	Gear 6th 25 T Countershaft
12	49221	2	KZ10-B		SEEGER	Snap Ring
13	48251	2	KZ10-B		RASAMENTO	Washer
14	19063	2	KZ10-B		GABBIA A RULLI	Needle cage
15	40503	1	KZ10-B		INGRANAGGIO 4a AS Z 27	Gear 4th 27 T Countershaft
16	40495	1	KZ10-B		INGRANAGGIO 3a AS Z 27	Gear 3rd 27 T Countershaft
17	40515	1	KZ10-B		INGRANAGGIO 5a AS Z 23	Gear 5th 23 T Countershaft
18	48012	1			RASAMENTO	Washer
19	40472	1			INGRANAGGIO 1a AS Z 33	Gear 1st 33 T Countershaft
20	19011	1			GABBIA A RULLI	Needle cage
21	48010	1			RASAMENTO	Washer

X ARTICOLI FUORI PRODUZIONE. CHI NECESSITA DI CAMBIARE L'ALBERO SECONDARIO (COD.40466) O LA SECONDA (COD.40484), DEVE AGGIORNARE IL CAMBIO CON IL KIT COD. 40468 (VEDI TAV.11 PAG.12)

Items no longer available. Who needs to change the countershaft (cod.40466) or the Second gear (cod. 40484), must update the gearbox with the kit code 40468 (SEE TAV.11 PAG.12)

**TAV. 10 – ALBERO SECONDARIO CAMBIO – Agg. Giugno 2014**  
(Countershaft – Update June 2014)

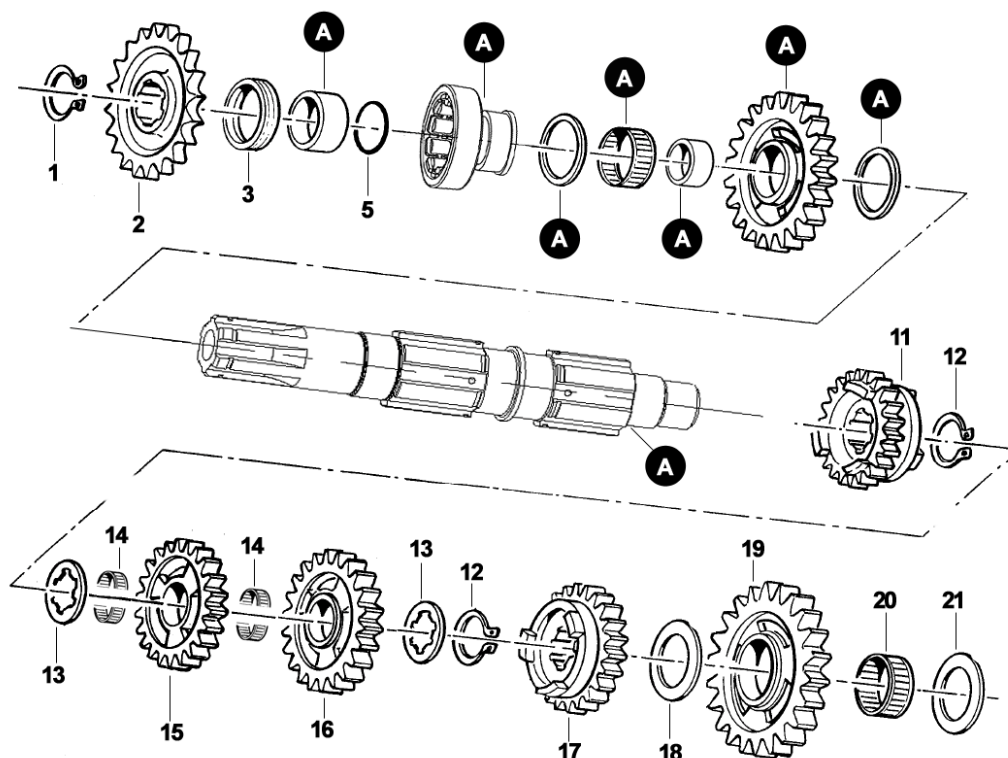

Pos	Codice	Q.tà	KZ10-B	Note	Descrizione (ITA)	Description (ENG)
1	49216	1			SEEGER	Snap Ring
2	40066.15	-			PIGNONE CATENA Z 15	Front Sprocket 15 T
	40066.16	-			PIGNONE CATENA Z 16	Front Sprocket 16 T
	40066.17	1			PIGNONE CATENA Z 17	Front Sprocket 17 T
	40066.18	-			PIGNONE CATENA Z 18	Front Sprocket 18 T
	40019	-			PIGNONE CATENA Z 19	Front Sprocket 19 T
	40020	-			PIGNONE CATENA Z 20	Front Sprocket 20 T
	40021	-			PIGNONE CATENA Z 21	Front Sprocket 21 T
3	04003	1			PARAOLIO	Oil Seal
5	12019	1			O-RING	O-Ring
11	40536	1	KZ10-B		INGRANAGGIO 6° AS Z 25	Gear 6th 25 T Countershaft
12	49221	2	KZ10-B		SEEGER	Snap Ring
13	48251	2	KZ10-B		RASAMENTO	Washer
14	19063	2	KZ10-B		GABBIA A RULLI	Needle cage
15	40503	1	KZ10-B		INGRANAGGIO 4a AS Z 27	Gear 4th 27 T Countershaft
16	40495	1	KZ10-B		INGRANAGGIO 3a AS Z 27	Gear 3rd 27 T Countershaft
17	40515	1	KZ10-B		INGRANAGGIO 5a AS Z 23	Gear 5th 23 T Countershaft
18	48012	1			RASAMENTO	Washer
19	40472	1			INGRANAGGIO 1a AS Z 33	Gear 1st 33 T Countershaft
20	19011	1			GABBIA A RULLI	Needle cage
21	48010	1			RASAMENTO	Washer
<b>A</b>	<b>40468</b>	1	<b>KZ10-B</b>		<b>KIT ALBERO SECONDARIO D. 21</b> (vedi TAV.11 pag. 12 per i dettagli)	<b>KIT COUNTERSHAFT D. 21</b> (see TAV.11 page 12 for details)

**Tav. 11 – KIT ALBERO SECONDARIO – Agg. Giugno 2014**  
(Kit Countershaft – Update June 2014)

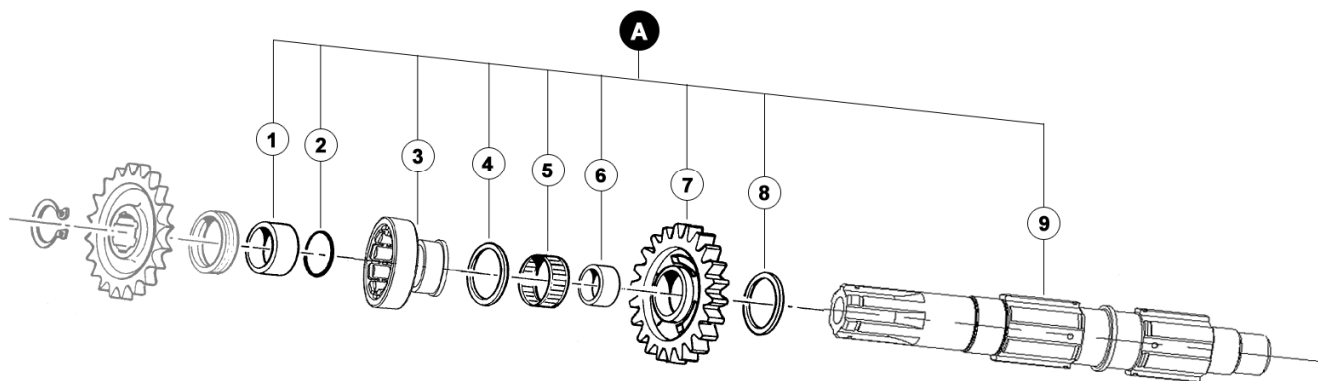

Pos	Codice	Q.tà	KZ10-B	Note	Descrizione (ITA)	Description (ENG)
<b>A</b>	<b>40468</b>	-	<b>KZ10-B</b>	<b>New</b>	<b>KIT ALBERO SECONDARIO D. 21</b> (include pos. 1+2+3+4+5+6+7+8+9)	<b>Kit Countershaft d.21</b> (include pos. 1+2+3+4+5+6+7+8+9)
1	26150	1	<b>KZ10-B</b>	<b>New</b>	<b>DISTANZIALE</b>	Spacer, sprocket
2	12019	1			<b>O-RING</b>	O-Ring
3	03073	1	<b>KZ10-B</b>	<b>New</b>	<b>CUSCINETTO A RULLI</b>	Roller bearing
4	48039	1	<b>KZ10-B</b>	<b>New</b>	<b>RASAMENTO</b>	Washer
5	19066	1	<b>KZ10-B</b>	<b>New</b>	<b>GABBIA A RULLI 24x28x10</b>	Needle cage
6	26149	1	<b>KZ10-B</b>	<b>New</b>	<b>BOCCOLA</b>	Collar
7	40486	1	<b>KZ10-B</b>	<b>New</b>	<b>INGRANAGGIO 2a AS Z 29</b> (PER IL MOMENTO NON DISPONIBILE COME RICAMBIO SEPARATO)	Gear 2 <sup>nd</sup> 29 T Countershaft (Not available as a spare part at the moment)
8	26152	1	<b>KZ10-B</b>	<b>New</b>	<b>RASAMENTO</b>	Washer
9	40467	1	<b>KZ10-B</b>	<b>New</b>	<b>ALBERO SECONDARIO</b> (PER IL MOMENTO NON DISPONIBILE COME RICAMBIO SEPARATO)	Countershaft (Not available as a spare part at the moment)

**TAV. 12 – DESMO CAMBIO**

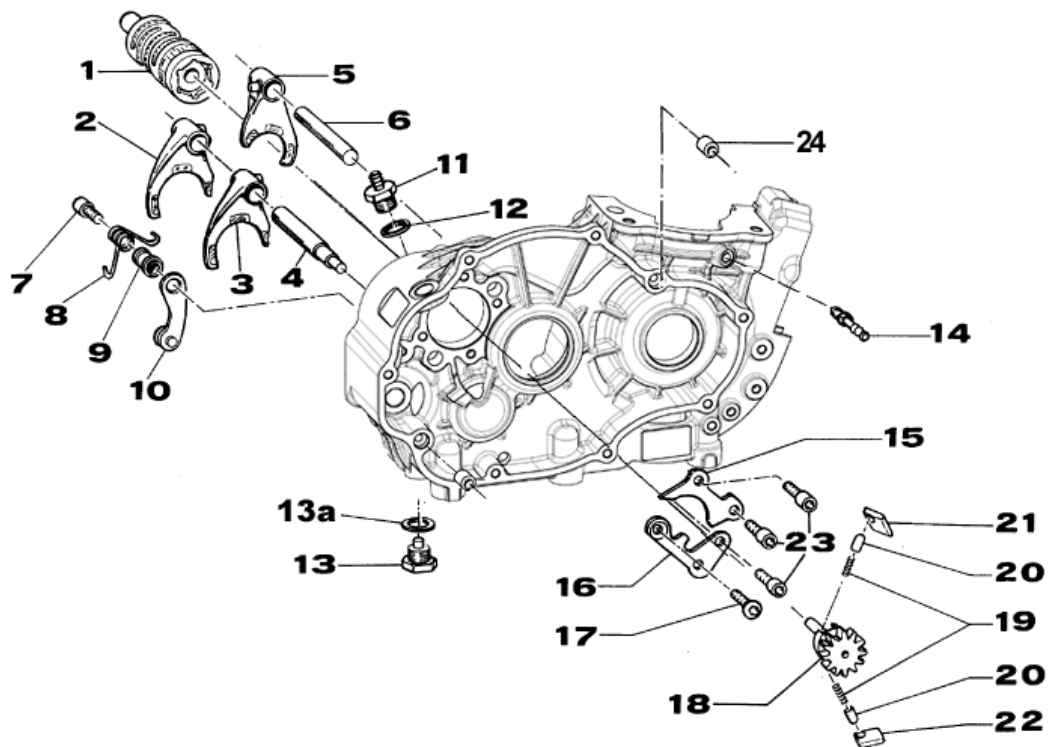

Pos	Codice	Q.tà	KZ10-B	Note	Descrizione (ITA)	Description (ENG)
1	33100	1	KZ10-B		ALBERO DESMODROMICO	
2	33013	1			FORCHETTA SECONDARIO	
3	33011	1			FORCHETTA SECONDARIO	
4	33096	1			PERNO FORCHETTE SECONDARIO	
5	33010	1			FORCHETTA PRIMARIO	
6	33020	1			PERNO FORCHETTA PRIMARIO	
7	49485	1			VITE TCEI 6 X 25	
8	16095	1			MOLLA BLOCCAMARCE	
9	26007	1			DISTANZIALE MOLLA	
10	26140	1	KZ10-B		PIASTRINO BLOCCAMARCE	
11	49302	1			TAPPO CON SFIATO	
12	49103	1			RONDELLA ALLUMINIO	
13	49851.1	1			TAPPO SCARICO OLIO	
13A	49118	1			RONDELLA	
14	49003.1	1			RACCORDO POMPA	
15	26096	1			PIASTRINO RIENTRO CRICCHETTI	
16	26094	1			PIASTRINO FINE CORSA	
17	49405	2			VITE TSEI 6 X 20 UNB.	
18	40310	1			INGRANAGGIO PORTACRICCHETTI	
19	16012	2			MOLLA PUNTALE	
20	26062	2			PUNTALE	
21	26060	1			CRICCHETTO SUPERIORE	
22	26061	1			CRICCHETTO INFERIORE	
23	49483	3			VITE TCEI 6 x 16	
24	26045	2			GRANO 10 x 8 F. 7	



**TAV. 13 – ACCENSIONE**  
(Ignition)

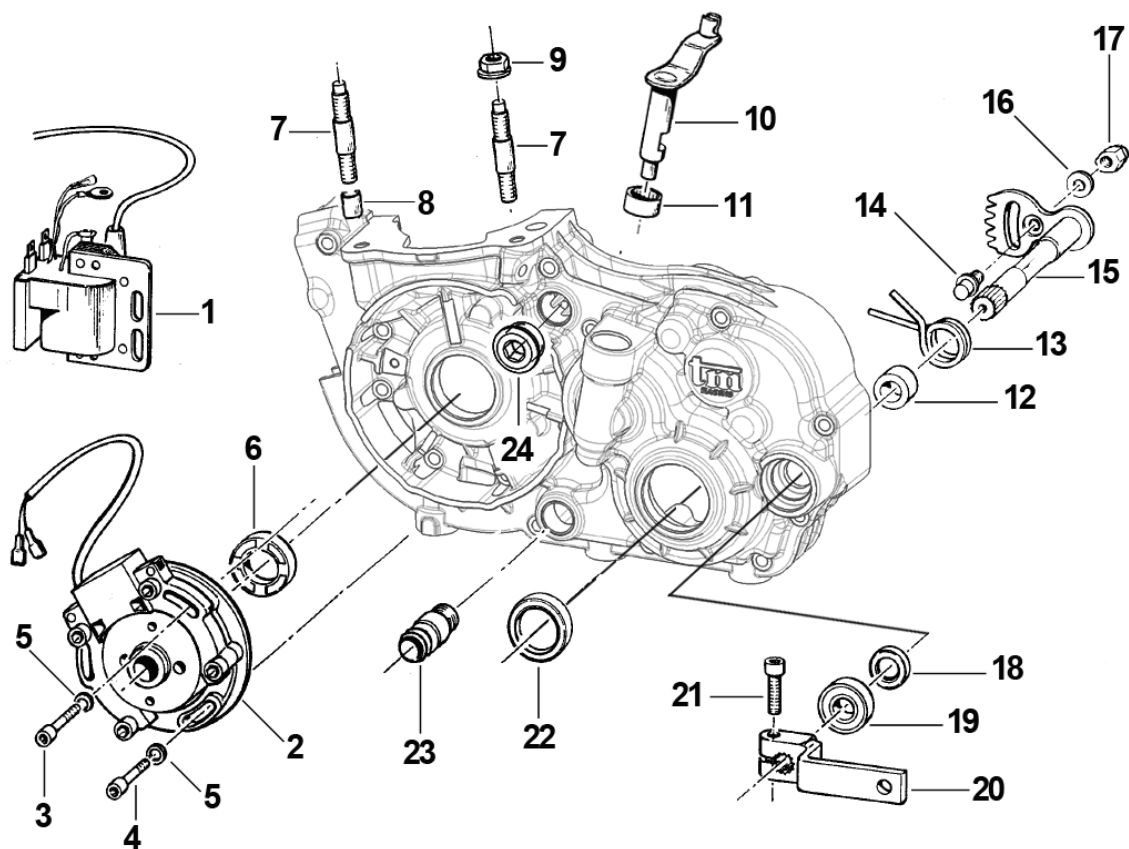

Pos	Codice	Q.tà	KZ10-B	Note	Descrizione (ITA)	Description (ENG)
1	15156	1			BOBINA PVL	Coil PVL
2	15155	1			ACCENSIONE	Ignition PVL
3	49479	2			VITE TCEI 5 x 40	Screw
4	49478	1			VITE TCEI 5 x 30	Screw
5	48007	3			RONDELLA ACCENSIONE	Washer
6	04000	1			PAROLIO 20 x 35 x 7	Oil Seal
7	49037	4	KZ10-B		PRIGIONIERO 8 x 61	Stud
8	26143	2	KZ10-B		BOCCOLA PRIGIONERO	Collar
9	49640	4			DADO CILINDRO	Nut
10	43011	1			LEVA COMANDO FRIZIONE	Lever, clutch
11	19042	1			GABBIA HK 14/14 RS	Needle bearing
12	26006	1			DISTANZIALE MOLLA LEVA CAMBIO	Sapcer
13	16010	1			MOLLA RITORNO LEVA CAMBIO	Spring
14	26053	1			BATTUTA ECCENTRICA	
15	28102	1			ALBERO COMANDO	
16	49603	1			RONDELLA 6 x 12	Washer
17	49635	1			DADO M 6 BASSO	Nut
18	04004	1			PARAOLIO 12 x 22 x 5	Oil Seal
19	03012	1			CUSCINETTO 6001 2 RS	Bearing
20	43003	1			LEVA CAMBIO	Lever, gear
21	49484	1			VITE TCEI 6 x 20	Screw
22	04003	1			PARAOLIO 26 x 37 x 7	Oil Seal
23	28018	1			RACCORDO ACQUA	Joint
24	49883	1	KZ10-B		TAPPO CIL/CARTER	Plug



**TAV. 14 – SCARICO + PIASTRA**  
(Exhaust and motor mount)

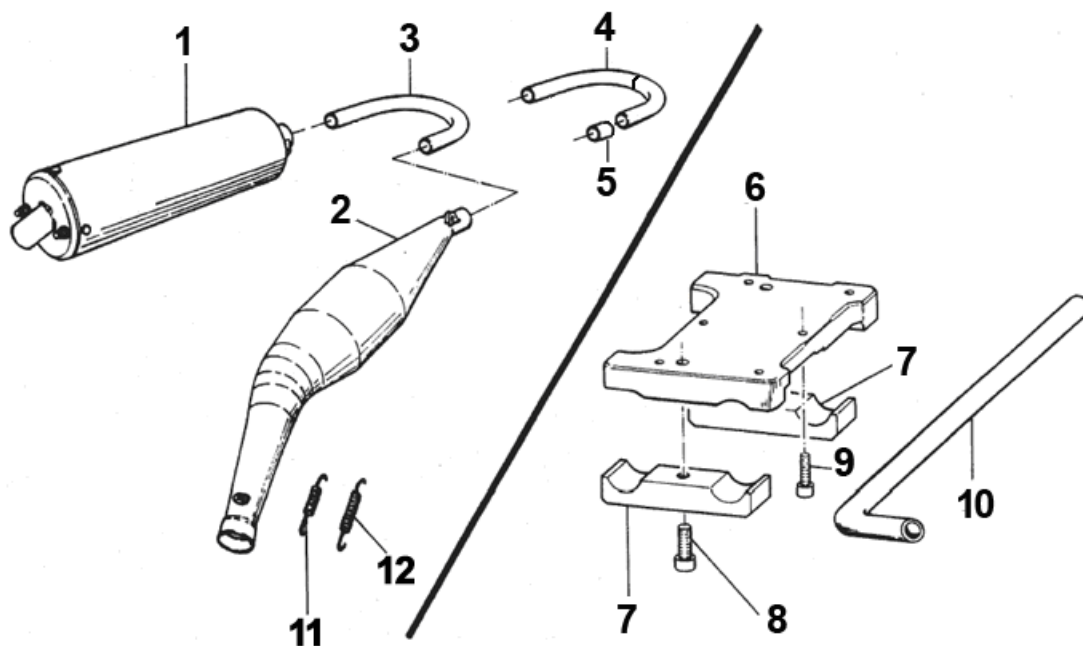

Pos	Codice	Q.tà	KZ10-B	Note	Descrizione (ITA)	Description (ENG)
1	27070.26	1			SILENZIATORE ALLUMINIO	Silencer
	27070.27	-			SILENZIATORE AR	Silencer
	27070.34	-			SILENZ. KART INOX CIK FIA – TD 5/EX-SI/22	
	27070.35	-			SILENZ. KART INOX CIK FIA – OVS 3/EX-SI/22	
	27070.36	-			SILENZ. KART INOX CIK FIA – OVD 4/EX-SI/22	
2	27000.28	1	KZ10-B		MARMITTA KZ10-B	Exhaust Pipe
3	27027.2	1			CURVA MARMITTA	U Band
4	27023	-			CURVA MARMITTA 26/28	U Band 26/28
5	27022.2	-			BOCCOLA CURVA	Collar, U Band 26/28
6	50156	1			SUPPORTO MOTORE NUDO	Motor Mount
7	50014	2			SOTTOSTAFFA SUPPORTO MOTORE	
8	49520	2			VITE TCEI 10 X 40	Bolt
9	49501	6			VITE TCEI 8 X 25	Bolt
10	21020	2			TUBO ACQUA	Hose, water
11	16003	2			MOLLA BICONICA	Spring
12	16002	-			MOLLA	Spring